



Shipping 2017: Challenges and Opportunities

Jan Otto de Kat | 24 January 2017
Malmo



© 2017 American Bureau of Shipping. All rights reserved

Regulatory Landscape

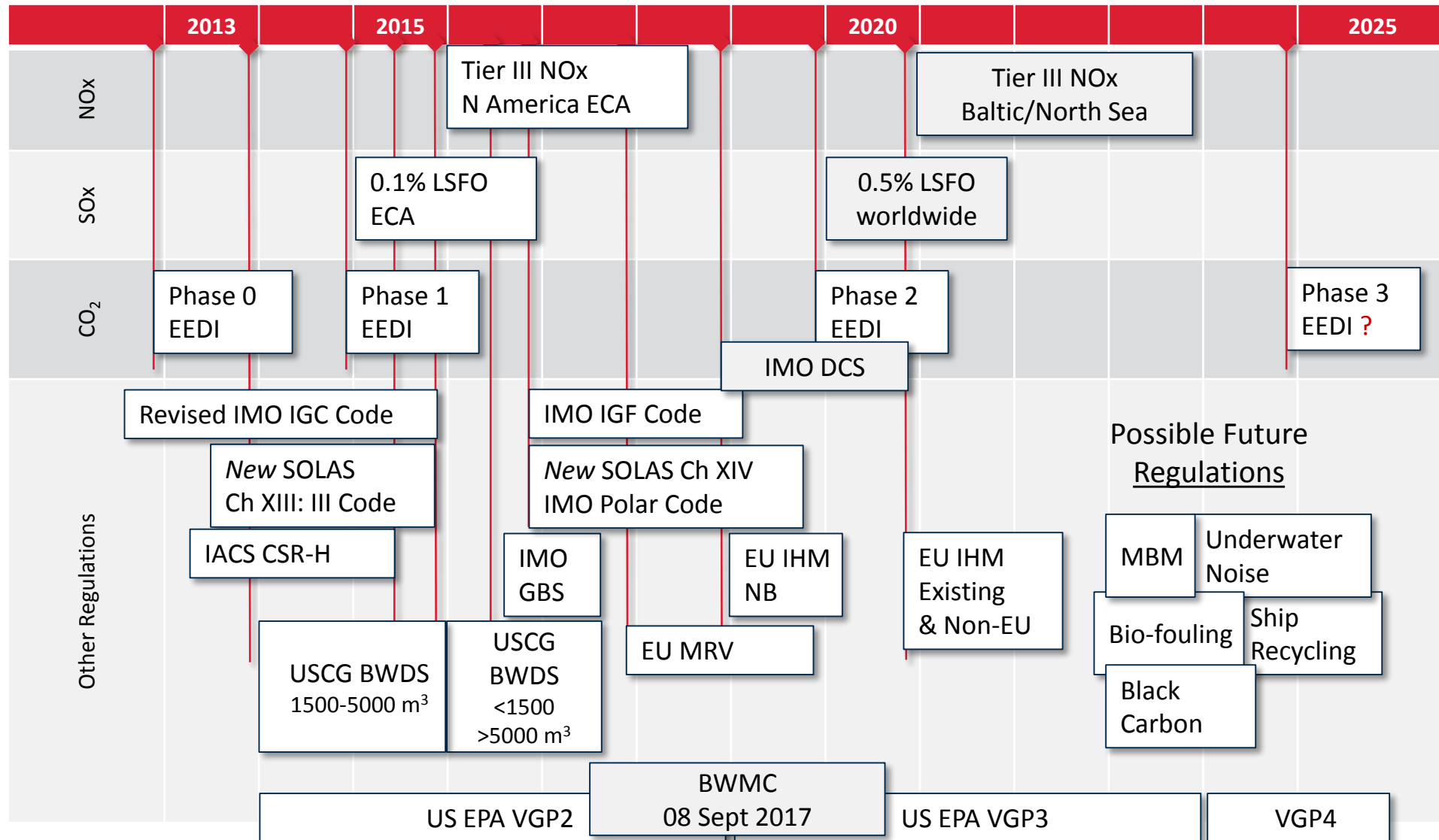

List of Acronyms

- BWDS Ballast Water Discharge Standard
- BWMC Ballast Water Management Convention
- CSR Common Structural Rules
- DCS Data Collection System
- EEDI Energy Efficiency Design Index
- GBS Goal Based Standards
- IGC Code International Code for the Construction and Equipment of Ships carrying Liquefied Gases in Bulk
- IGF Code International Code of Safety for Ship Using Gases or Other Low-flashpoint Fuels
- IHM Inventory of Hazardous Materials
- LSFO Low Sulphur Fuel Oil
- MBM Market Based Measures
- VGP Vessel General Permit

CO₂: IMO Data Collection System (DCS)

- Collection and reporting of ship fuel consumption data, all ships > 5,000 GT on international voyages

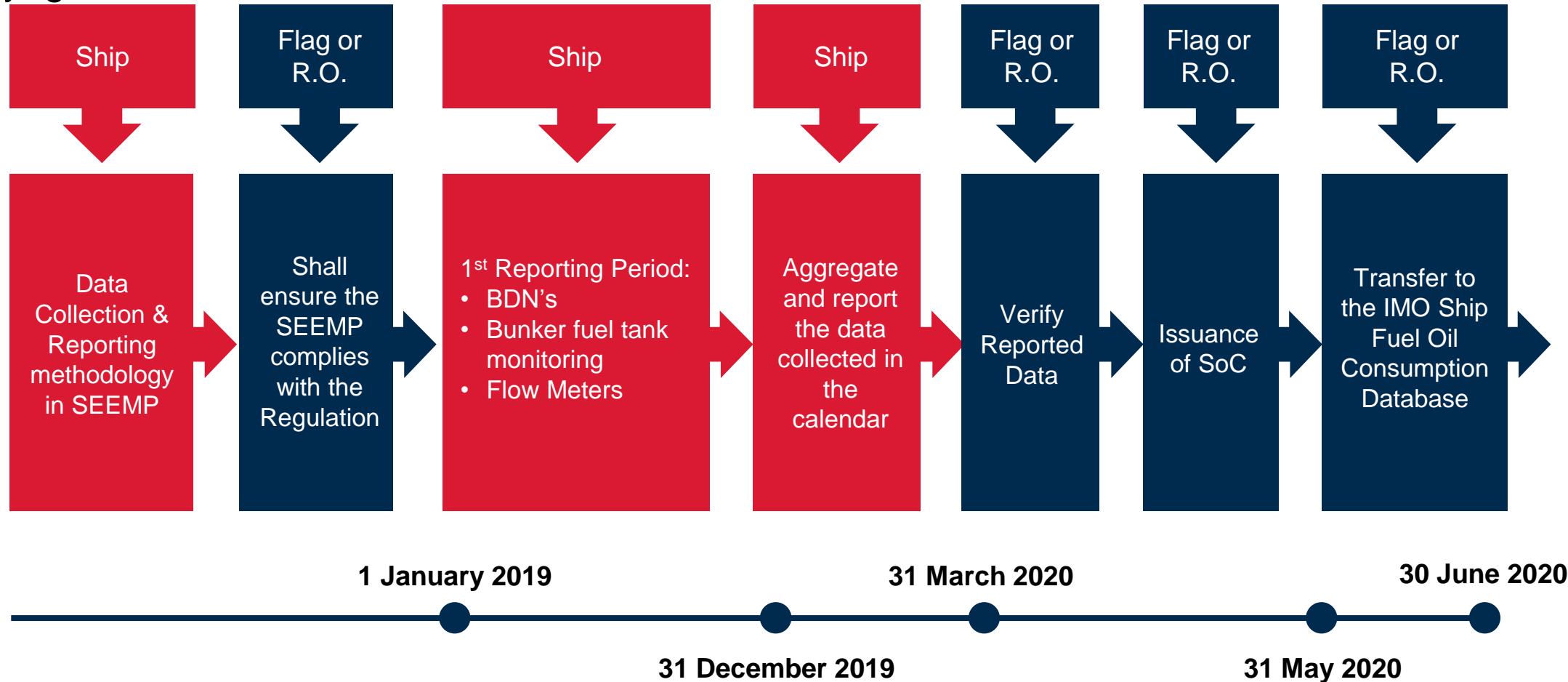

CO₂: EU Monitoring, Reporting and Verification

- Ships above 5,000 GT on voyages to, from and between EU ports

